

INSTALLATION



cVEND box / box+

Terminal for Contactless Payment, Ticketing and Vending



Note

© Copyright 2017 by
FEIG ELECTRONIC GmbH
Lange Strasse 4
D-35781 Weilburg
Tel.: +49 6471 3109-0
<http://www.feig.de>

With the edition of this document, all previous editions become void. Indications made in this manual may be changed without previous notice.

The reproduction, distribution and utilization of this document as well as the communication of its contents to others without express authorization is prohibited. Offenders will be held liable for the payment of damages. All rights reserved in the event of the grant of a patent, utility model or design.

Composition of the information in this document has been done to the best of our knowledge. FEIG ELECTRONIC GmbH does not guarantee the correctness and completeness of the details given in this manual and may not be held liable for damages ensuing from incorrect or incomplete information. Since, despite all our efforts, errors may not be completely avoided, we are always grateful for your useful tips.

The instructions given in this manual are based on advantageous boundary conditions. FEIG ELECTRONIC GmbH does not give any guarantee promise for perfect function in cross environments and does not give any guaranty for the functionality of the complete system which incorporates the subject of this document.

FEIG ELECTRONIC call explicit attention that devices which are subject of this document are not designed with components and testing methods for a level of reliability suitable for use in or in connection with surgical implants or as critical components in any life support systems whose failure to perform can reasonably be expected to cause significant injury to a human. To avoid damage, injury, or death, the user or application designer must take reasonably prudent steps to protect against system failures.

FEIG ELECTRONIC GmbH assumes no responsibility for the use of any information contained in this document and makes no representation that they free of patent infringement. FEIG ELECTRONIC GmbH does not convey any license under its patent rights nor the rights of others.

All brand names, trademarks or logos are property of their respective owners.

Contact:

Technical Questions: cvend-support@feig.de

Contents

1. Warning - Read before start-up !	4
1.1. Safety Instructions	4
1.2. Security Instructions	4
2. Characterization	5
2.1. Functional Elements	6
3. Mechanical Installation	7
3.1. Dimensions	8
3.2. Recommended Front Panel Cutout	9
3.3. Recommended Mounting Frame	10
4. Connection	11
4.1. Connector X7 – Power Supply and MDB Interface	12
4.2. Connector X1 - Ethernet Interface	13
4.3. Connector X2 - USB Device Interface	14
4.4. Connector X3 - RS232 V.24 (UART#1) Interface	15
4.5. Connector X8 - USB Host Interface	16
4.6. Wake-Up	16
4.7. SAM Sockets	17
4.8. microSD socket	18
4.8.1. Recommended microSD Cards	18
5. Signals	19
5.1. Boot Process	19
5.2. Security Tamper	19
6. Technical Data	20
6.1. Standard Compliance	21
6.1.1. Declaration of Conformity - Europe (CE)	21
6.1.2. Radio Approval - USA (FCC) and Canada (IC)	22

1. Warning - Read before start-up !

1.1. Safety Instructions

- The device may only be used for the intended purpose designed for by the manufacturer.
- The operation manual should be conveniently kept available at all times for each user.
- Unauthorized changes and the use of spare parts and additional devices which have not been sold or recommended by the manufacturer may cause fire, electric shocks or injuries. Such unauthorized measures shall exclude any liability by the manufacturer.
- The liability-prescriptions of the manufacturer in the issue valid at the time of purchase are valid for the device. The manufacturer shall not be held legally responsible for inaccuracies, errors, or omissions in the manual or automatically set parameters for a device or for an incorrect application of a device.
- Repairs may only be executed by the manufacturer.
- Installation, operation, and maintenance procedures should only be carried out by qualified personnel.
- Use of the device and its installation must be in accordance with national legal requirements and local electrical codes .
- When working on devices the valid safety regulations must be observed.
- Special advice for carriers of cardiac pacemakers:
Although this device doesn't exceed the valid limits for electromagnetic fields you should keep a minimum distance of 25 cm between the device and your cardiac pacemaker and not stay in an immediate proximity of the device respective the antenna for some time.

1.2. Security Instructions

- The information's given in the separate document cVEND Security Policy must be observed!
- **DO NOT DISASSEMBLE ANY PART!** The device contains a battery-powered security circuited. The security circuit will be triggered if security relevant parts are disassembled. In such cases the device stops regular operation and can be reactivated only by the manufacturer in a certified secure environment.

2. Characterization

The cVEND box is a secure terminal for contactless credit cards and public transport tickets. It fulfills the latest functional and security related payment card industry standards.

cVEND box is designed for integration into kiosk systems and vending machines. cVEND box is available in a version without display (cVEND box) and with display (cVEND box+).



cVEND box



cVEND box+

2.1. Functional Elements

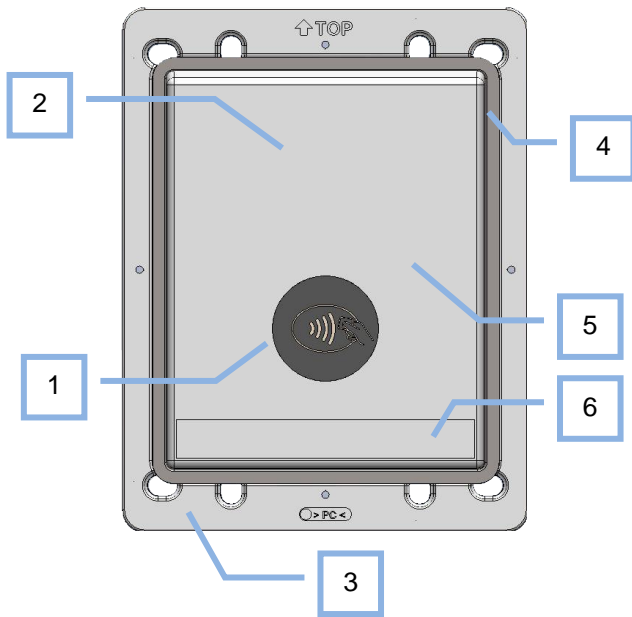

Fig. 1: cVEND box front view - not installed

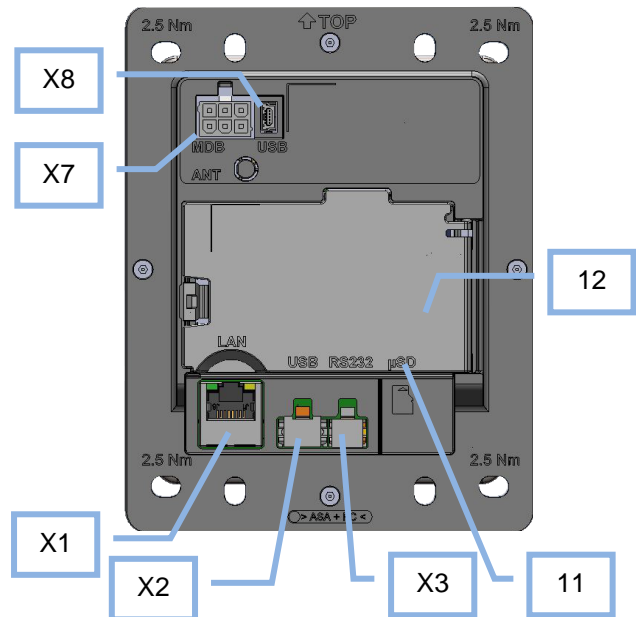

Fig. 2: cVEND box rear view - not installed

Table 1: Interfaces and connectors

Number	Label	Description
1	-	Antenna with illuminated contactless payment symbol
2	-	Display position (cVEND box+ only)
3	-	Mounting flange
4	-	Sealing
5	-	LED position (4 x green, 1 x yellow, 1 x red)
6	-	Label area for custom specific labeling
X7	MDB	Connector for Power Supply and MDB Interface
X1	LAN	Ethernet Connector
X2	USB Device	USB Device Connector
X3	RS232	RS232 Connector
X8	USB Host	USB Host Connector
11	μSD	μSD Socket (access when latch is open)
12	SAM	4 SAM Sockets (access when latch is open)

3. Mechanical Installation

The cVEND box is intended to be installed into a front panel from the back side as shown in Fig. 1 . The mechanical dimensions, necessary cut out and mounting fixing point are designed in accordance with the vending machine standard EVA CVS 1.3, Appendix F.



Fig. 1 cVEND box installation

Recommended front plate thickness: max. 5 mm

Recommended torque:

max. 2,5 Nm	If mounted with washer and nut.
max. 5,0 Nm	If mounted with additional Mounting Frame

3.1. Dimensions

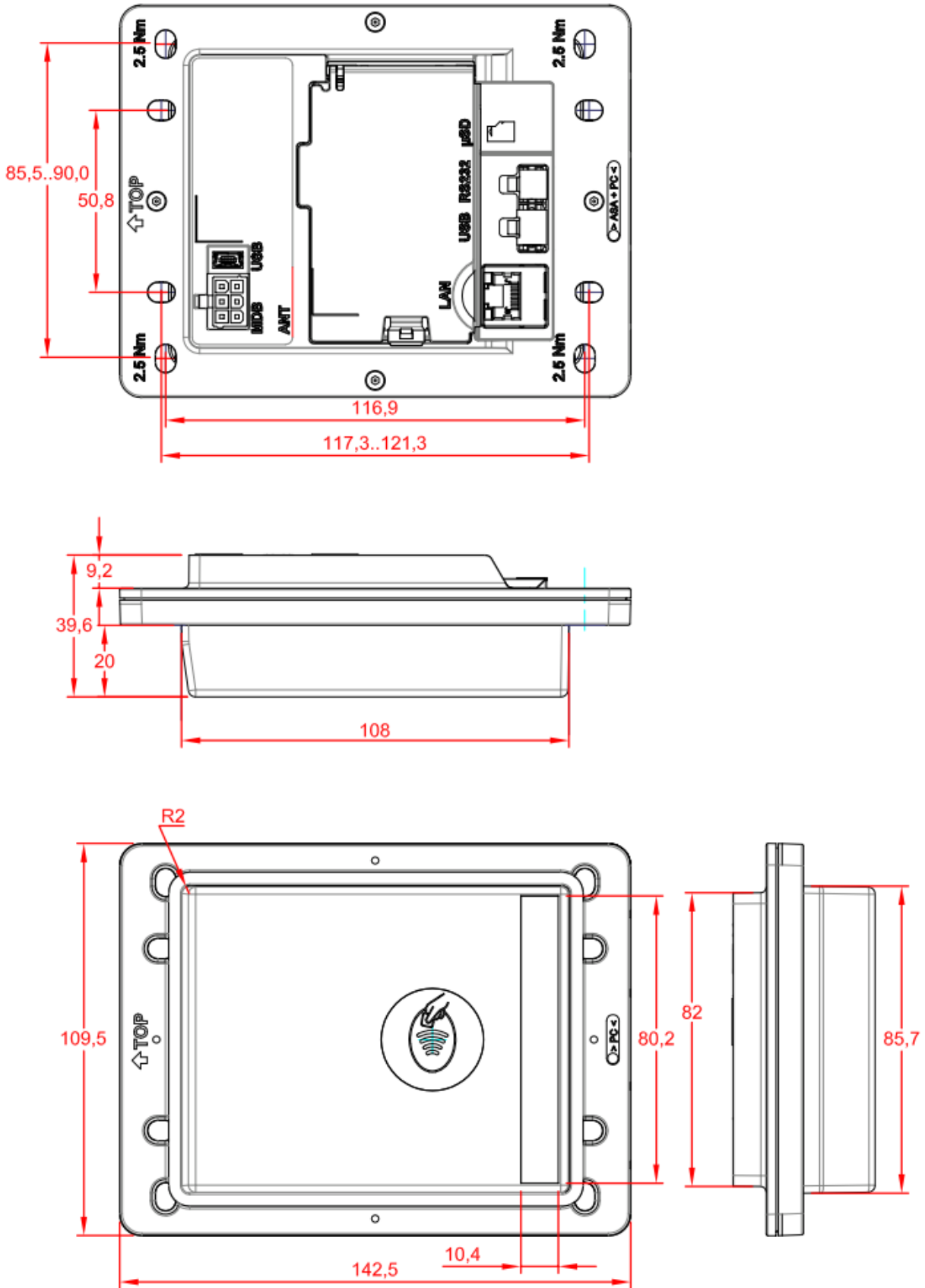

Fig. 2 cVEND box - Dimensions

3.2. Recommended Front Panel Cutout

Fig. 3 shows the cutout according EVA CVS standard which is recommend for installation of cVEND box. For mounting 4 threaded bolt (M4 x 20 mm) attached to the front panel are recommended.

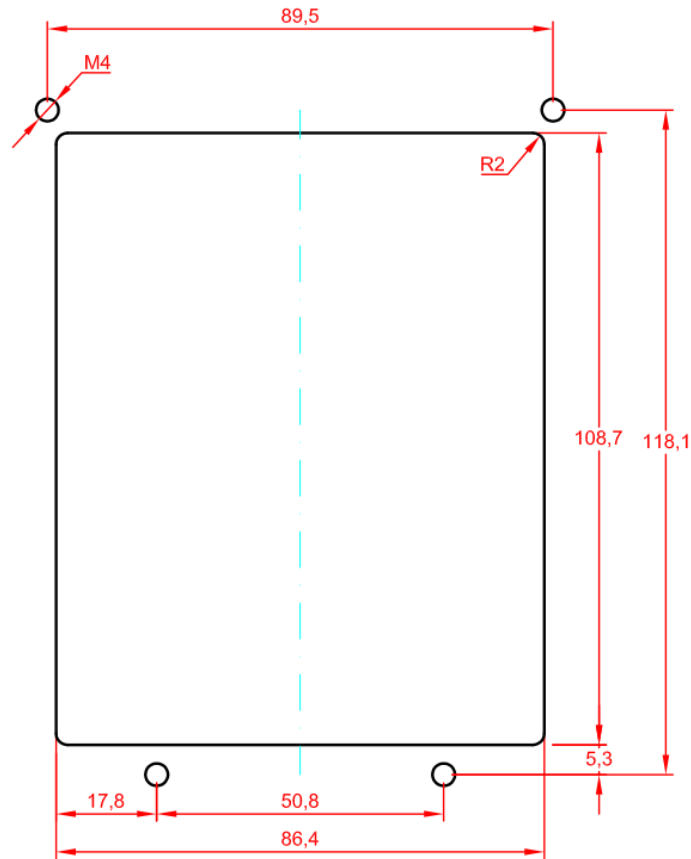

Fig. 3 Recommended front panel cutout for cVEND box



Fig. 4 Picture of front panel cutout for cVEND box with 4 threaded bolts

3.3. Recommended Mounting Frame

In order to achieve a good mechanical resistance against external mechanical influences like vandalism a additional robust mounting frame (e.g. 3 mm Steel) is recommended to be placed behind the mounting flange of the cVEND box.

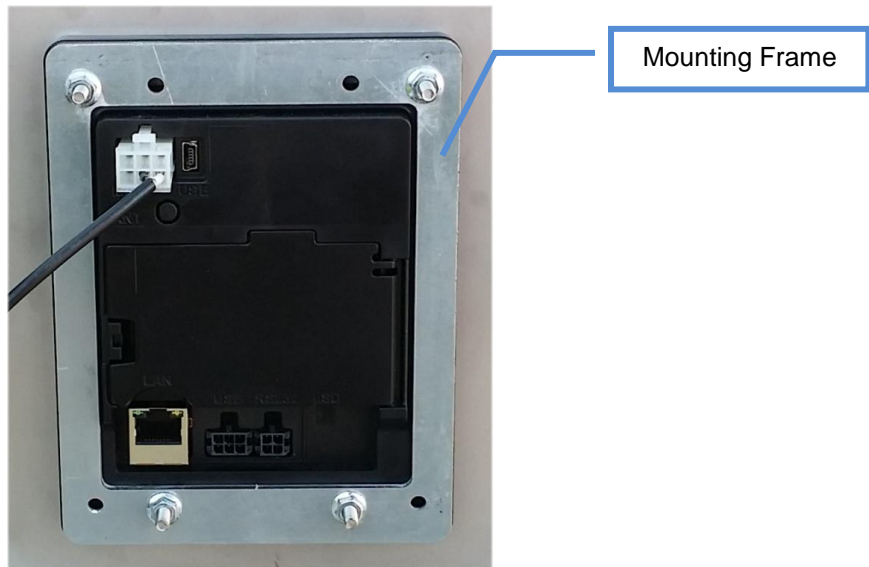

Fig. 5 Picture of cVEND box installed with mounting frame

4. Connection

The connector I/O PINs are described from the cVEND box view. A cVEND box input must be connected to one output or vice versa.

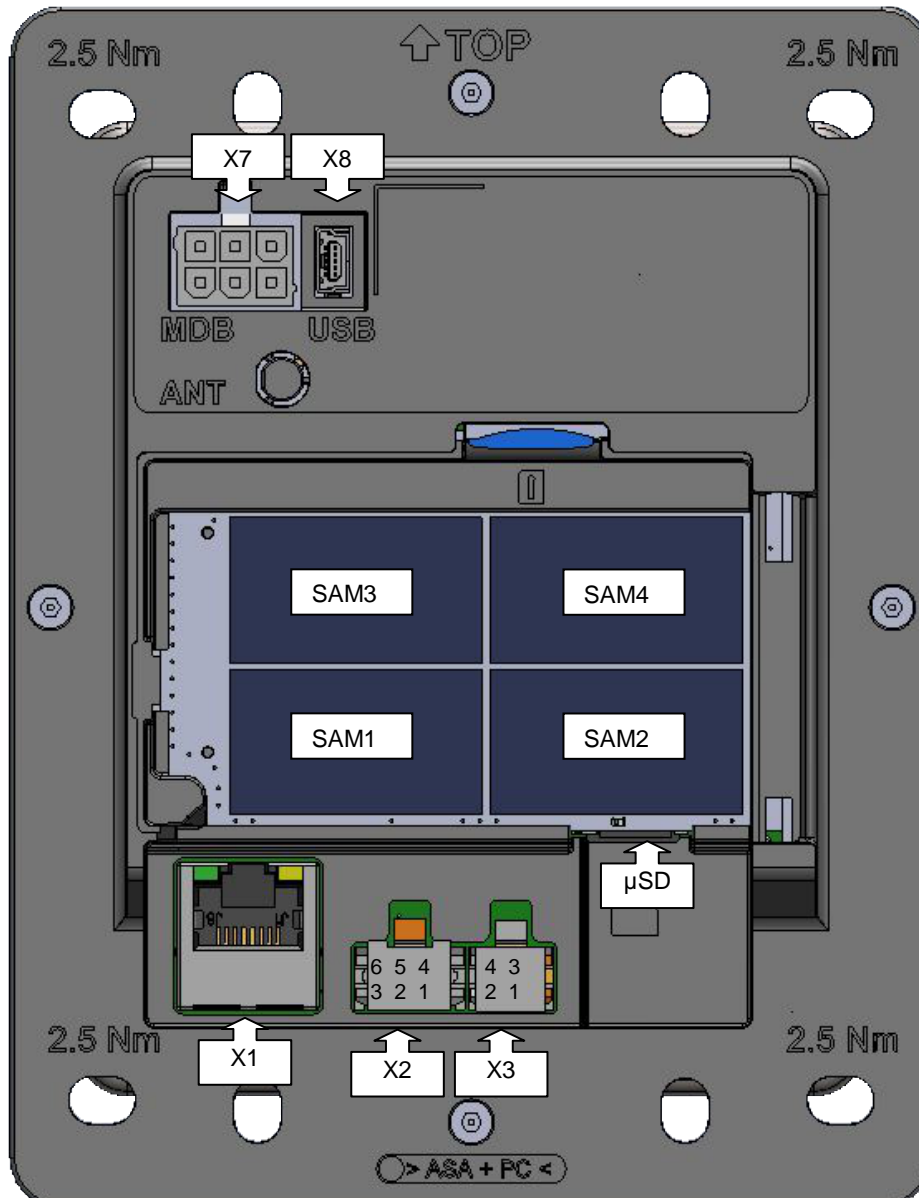

Fig. 6 cVEND box - connector location

4.1. Connector X7 – Power Supply and MDB Interface

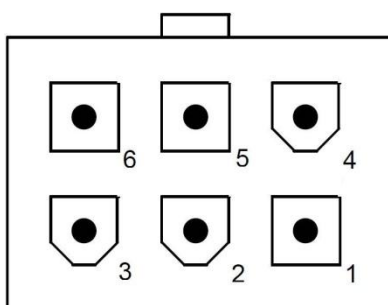

Fig 1: Pin assignment MDB connector

Table 2: Pin assignment MDB connector

Pin	Label	Direction
1	Power Supply - Vcc (V DC 12 to 42 V DC)	-
2	Power Supply - GND	-
3	Wakeup	I/O
4	MDB Master Receive	O
5	MDB Master Transmit	I
6	MDB Communications Common	-

Required Connector:

The fitting complement for this connector consists of a 6-pole plug Type Molex Mini Fit and the appending Crimp contact.

Manufacturer ordering code:

Molex 39-01-2060

Plug 6pole, grid dimension 4,2, 2-rowed, Molex Mini Fit housing

Molex 39-00-0065

Crimp contact, Female, grid dimension 4,2, AWG#22-28, Molex Mini Fit

NOTE:

The reader has to be supplied by a limited power supply (e.g. NEC Class 2/LPS power supply) according IEC EN 60950-1 chapter 2.5, only.

Supply voltages outside the specifications may destroy the device.

4.2. Connector X1 - Ethernet Interface

cVEND has an integrated 10 / 100 Base-T network port at RJ45 connector X1, with automatic polarity correction during auto-negotiation and 10 Base-T signal reception.

CAT 5 cables are recommended to ensure a reliable operation at 10 Mbps or 100 Mbps.

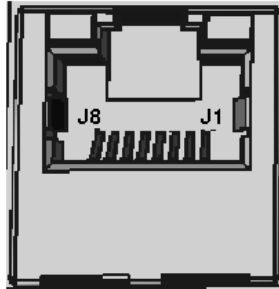

Fig. 3: Ethernet Interface at connector X1

Required Connector: RJ45

Table 3: Pin Assignment Ethernet Connector

PIN	Label
1	TX+
2	TX-
3	RX+
4	VETH+
5	VETH+
6	RX-
7	VETH-
8	VETH-

4.3. Connector X2 - USB Device Interface

At connector X2 a USB-Device interface is provided where USB-Host can be connected. cVEND is designed as a self powered device. powering over USB interface is not possible.

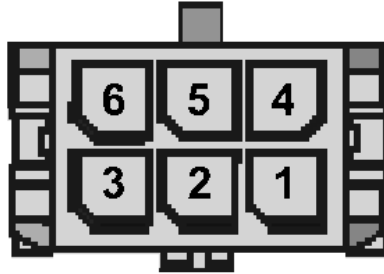

Fig. 4: USB Interface at connector X2

Required Connector:

The fitting complement for this connector consists of a 6-pole plug Type Molex Micro Fit and the appending Crimp contact.

Manufacturer ordering code:

Molex 43025-0600

Plug, 6-pole, grid dimension 3.0 mm, Dual Row, Molex Micro Fit housing

Molex 43030-0001

Crimp contact, Female, grid dimension 3.0 mm, AWG#20-24, Molex Micro Fit

Table 4: Pin Assignment USB Connector

PIN	Label	Direction
1	DEV-Vcc	I
2	DEV-D-	I/O
3	DEV-D+	I/O
4	N.C.	-
5	GND	-
6	Shield	-

NOTE:

The USB interface is specified for max. 5 m (20 inch) cable length.

4.4. Connector X3 - RS232 V.24 (UART#1) Interface

X3 is the connector for a RS232 interface on V.24 level.

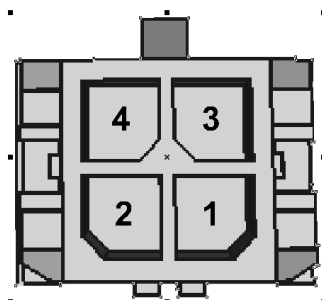

Fig. 5: RS232 V.24 (UART#1) Interface at connector X3

Required Connector:

The fitting complement for this connector consists of a 4-pole plug Type Molex Micro Fit and the appending Crimp contact.

Manufacturer ordering code:

Molex 43025-0400

Plug, 4-pole, grid dimension 3.0 mm, Dual Row, Molex Micro Fit housing

Molex 43030-0001

Crimp contact, Female, grid dimension 3.0 mm, AWG#20-24, Molex Micro Fit

Table 5: Pin Assignment RS232 V.24 Interface

PIN	Label	Direction	Remark
1	cVEND RXD	I	
2	cVEND TXD	O	
3	Wake-UP	I/O	see 4.6. Wake-Up
4	GND	-	

4.5. Connector X8 - USB Host Interface

At connector X8 a USB-Host interface is provided where USB-device can be connected. USB-Host function depends on Firmware / Software Version.

Required Connector:

USB Mini

4.6. Wake-Up

cVEND offers a standby mode which can be configured via software commands. If standby is activated the bidirectional Wake-Up I/O is used for signaling a wake-up event by the cVEND and can be used by the host to activate the cVEND.

Wake-Up by host:

The host controller can awake the cVEND by pulling down the Wake-Up line.

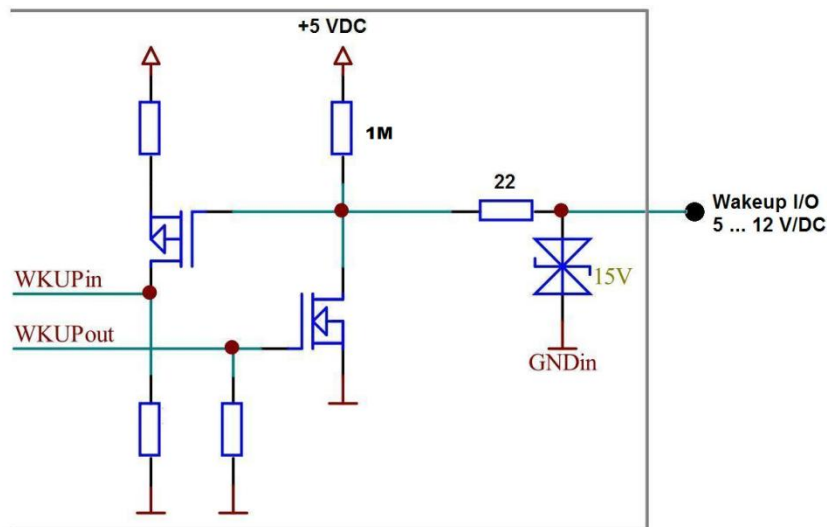

Fig. 6: cVEND internal Wake-Up circuit

NOTE:

If the standby - Wake-Up option is used in connection with the USB interface the USB connection will be interrupted while standby mode.

4.7. SAM Sockets

cVEND box is equipped with 4 SAM sockets which are located behind the latch on the backside of the device.

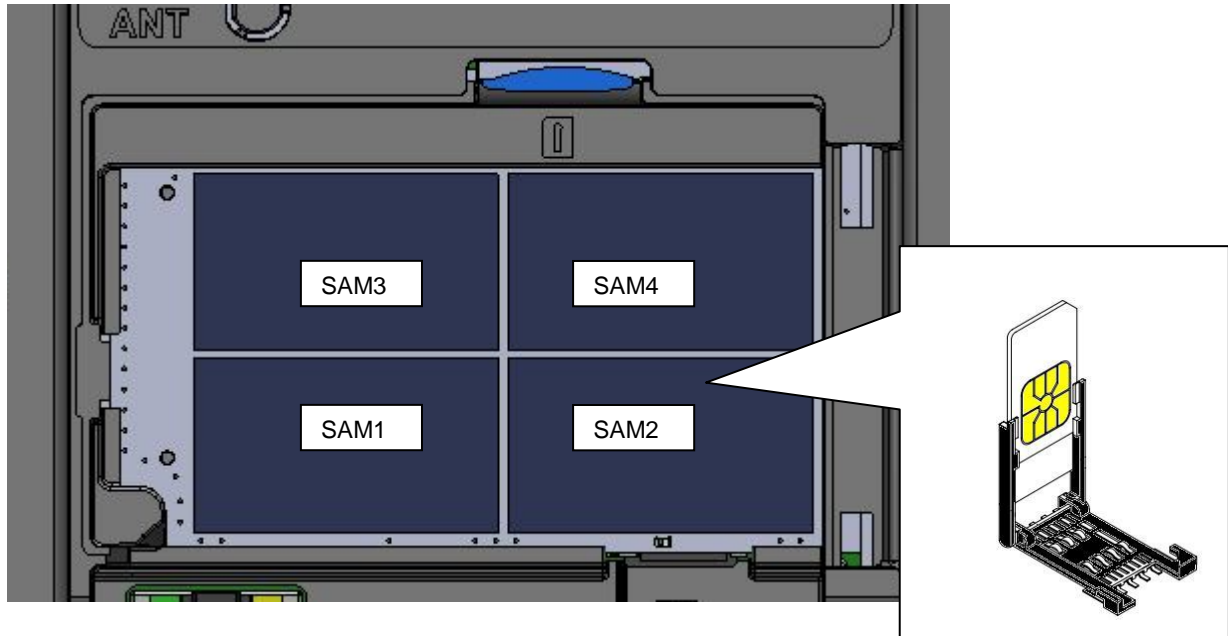

Fig. 7 cVEND box - SAM socket location and handling

4.8. microSD socket

cVEND box is equipped with a socket for microSD memory cards, which is accessible behind the latch on the backside.



Fig. 8 cVEND box - microSD memory card insertion

4.8.1. Recommended microSD Cards

The following tables shows memory cards which are tested with cVEND

Manufacturer / Type	Specification
ATP AF1GUDI-OEM-ND	1 GB, SLC, Class 6
ATP AF8GUDI-OEM-ND	8 GB, SLC, Class 10
Panasonic PCR234-ND	4 GB, MLC, Class 2
swissbit 1052-1108-ND	2 GB, SLC, Class 6
Xmore (GLYN) SDU-4G0-XQc8(010)	4 GB, MLC, Class 10

5. Signals

This chapter describes the signals generated by the cVEND operating system. In normal operation mode the cVEND user interface is controlled by the respective application.

5.1. Boot Process

1 x beep	Indicates that the cVEND is powered and has started the boot process. Booting-routine needs approx one minute.
1 x  1 x beep	1 x green LEDs: Indicates that the boot process is finished

5.2. Security Tamper

NOTICE:

The information's given in the separate document **cVEND Security Policy** must be observed!

The device contains tamper mechanisms that will trigger when a physical penetration attempt of the device is detected. A tamper event is signaled by cVEND after power on.

 beep ... beep ... beep	Tamper Event <ul style="list-style-type: none"> • Red LED on and intermitting beep: Tamper Event • Tamper message send out cyclic on the serial port UART#1, Connector X3 at 57.600 Baud, 8-N-1 (starting with Firmware 01.05.19, this message is send out on all serial ports) • cVEND stops regular operation.
---	---

6. Technical Data

		box	box+	
Housing Material /Flammability	<ul style="list-style-type: none"> Plastic (PC; PC+ABS) / UL94-V0 	✓	✓	
Dimensions over all (W x H x D)	<ul style="list-style-type: none"> 110 x 142.5 x 40 mm (EVA CVS compliant) 	✓	✓	
Dimensions visible (W x H x D)	<ul style="list-style-type: none"> 86 x 108 x 15 mm 			
Protection Class	Front Side	<ul style="list-style-type: none"> IP65 (if accurate installed) 	✓	✓
Impact protection Class		<ul style="list-style-type: none"> IK10 	✓	✓
Temperature Range	Operating	<ul style="list-style-type: none"> -30 °C to +70 °C 	✓	✓
	Storage	<ul style="list-style-type: none"> -30 °C to +80 °C 	✓	✓
Humidity		<ul style="list-style-type: none"> 5 % to 95 % (no condensing) 	✓	
Power Supply		<ul style="list-style-type: none"> 12 to 42 V DC ± 5% (Ripple < 1% pp) 	✓	✓
Power Consumption		<ul style="list-style-type: none"> max. 8 W 	✓	✓
Standby Mode		<ul style="list-style-type: none"> < 35 mA, Full operation after wake-up ≤ 1 Sec Wakeup digital input 	✓	✓
RFID Interface		<ul style="list-style-type: none"> Integrated Antenna 13,56 MHz ISO/IEC 14443-A / -B (NFC reader/writer mode) in EMVCo contactless mode Hardware enabled for NFC IP1 (P2P), NFC card emulation, JIS X 6319-4 (Sony Felica) 	✓	✓
Supported Transponder		<ul style="list-style-type: none"> ISO/IEC 14443-4 compliant smart cards, NFC Type 1, 2 and 4 in card emulation mode, mifare classic, mifare DESFire EV1, mifare ultralight 	✓	✓
Peripheral Interfaces		<ul style="list-style-type: none"> Ethernet - IEEE 802.3/Ethernet, 10/100 Mbps; RJ45 Connector (X1) RS232 (V.24); Molex Micro Fit connector (X3) USB 2.0 Host; 12 MBit/s; max 500 mA; USB mini connector (X8) USB 2.0 Device; 12 MBit/s; Self powered device; Molex Micro Fit connector (X2) MDB Slave; MDB standard connector (X7) 	✓	✓
User Interface		<ul style="list-style-type: none"> 6 LED (4 green, 1 red, 1 yellow) Buzzer Illuminated Payment Logo Graphical OLED Display (yellow) 128 x 32 Pixel 	✓	✓
CPU and Security		<ul style="list-style-type: none"> ARM 9 CPU (384 MHz) – Tamper Protected and Side Channel Attack Resistant with Real Time Memory Encryption Cryptographic Hardware Acceleration supports SHA, DES, AES True Random Number Generator RAM MByte 128 / FLASH MByte 256 Real Time Clock – Battery backed 	✓	✓
SAM Interface - ISO7816		<ul style="list-style-type: none"> 4 x SAM Sockets for ID000 Format (SIM-Card) T=0 and T=1 Protocol support of power class A, B, C 	✓	✓

microSD Socket	<ul style="list-style-type: none"> SD Host Controller Version 2.0 for SD/SDHC class 10 memory card 	✓	✓
Battery	<ul style="list-style-type: none"> 3V Lithium Battery, 540 mAh, Lifetime 10 years at 25 °C¹ 	✓	✓
MTBF at 55 °C (EN61709)	<ul style="list-style-type: none"> 100.000 h 62.000 h 	✓	✓

6.1. Standard Compliance

Radio Approval	Europe <ul style="list-style-type: none"> EN 300 330 USA <ul style="list-style-type: none"> FCC 47 CFR Part 15 Canada <ul style="list-style-type: none"> IC RSS-Gen, RSS-210
EMC	<ul style="list-style-type: none"> EN 301 489
Safety and Health	<ul style="list-style-type: none"> EN 60950 EN 50364
Hazardous Substances	<ul style="list-style-type: none"> RoHS - 2011/65/EC
Electrostatic Discharge	<ul style="list-style-type: none"> ISO 10605, Category 3
Protection Class (Front Side)	<ul style="list-style-type: none"> EN 60529, IP65 (if accurate installed)
Impact protection Class	<ul style="list-style-type: none"> IEC 62262, IK10
Shock and Vibration	<ul style="list-style-type: none"> IEC 60068-2-6 / IEC 60068-2-27
Payment	<ul style="list-style-type: none"> EMVCo 2.3.1a Contactless Level 1 PCI PTS 4.x, SRED incl. Open Protocol
Contactless Payment Kernel (Optional)	<ul style="list-style-type: none"> MasterCard contactless VISA Paywave American Express Expresspay Discover D-PAS

6.1.1. Declaration of Conformity - Europe (CE)

Herby, FEIG ELECTRONIC GmbH declares that the radio equipment type cVEND box / box+ is in compliance with Directive 2014/53/EU.

The full text of the EU declaration of conformity is available at the following internet address:
www.feig.de

¹ Battery is needed for security function and RTC.

6.1.2. Radio Approval - USA (FCC) and Canada (IC)

Product name:	cVEND plug
FCC ID: IC:	PJMCVEND 6633A-CVEND
PMN: HVIN: HMN:	cVEND cVEND plug cVEND plug
Notice for USA and Canada	<p>This device complies with Part 15 of the FCC Rules and with RSS-210 of Industry Canada.</p> <p>Operation is subject to the following two conditions.</p> <p>(1) this device may not cause harmful interference, and</p> <p>(2) this device must accept any interference received, including interference that may cause undesired operation.</p> <p>Unauthorized modifications may void the authority granted under Federal communications Commission Rules permitting the operation of this device.</p> <p>This equipment has been tested and found to comply with the limits for a Class A digital device, pursuant to Part 15 of the FCC Rules. These limits are designed to provide reasonable protection against harmful interference when the equipment is operated in a commercial environment. This equipment generates, uses, and can radiate radio frequency energy and, if not installed and used in accordance with the instruction manual, may cause harmful interference to radio communications. Operation of this equipment in a residential area is likely to cause harmful interference in which case the user will be required to correct the interference at his own expense.</p> <p>Le présent appareil est conforme aux CNR d'Industrie Canada applicables aux appareils radio exempts de licence. L'exploitation est autorisée aux deux conditions suivantes :</p> <p>(1) l'appareil ne doit pas produire de brouillage, et</p> <p>(2) l'utilisateur de l'appareil doit accepter tout brouillage radioélectrique subi, même si le brouillage est susceptible d'en compromettre le fonctionnement.</p>

Installation with FCC / IC Approval:

FCC-/IC-NOTICE: To comply with FCC Part 15 Rules in the United States / with IC Radio Standards in Canada, the system must be professionally installed to ensure compliance with the Part 15 certification / IC certification. It is the responsibility of the operator and professional installer to ensure that only certified systems are deployed in the United States / Canada.

Installation instructions to the host manufacturer

Changes or modifications made to the equipment not expressly approved by FEIG ELECTRONIC GmbH may void the FCC / IC authorization to operate this equipment.

The use of the transceiver module is authorized in mobile or fixed host devices taking into account the conditions listed below:

- OEM Integrator must ensure that the end user manual may not contain any information about the way to install or remove the module from the final product.
- Depending on the final host device additional authorization requirements for the non-transmitter functions of the transmitter module may be required (i.e., Verification, or Declaration of Conformity) The OEM integrator is responsible for ensuring that after the module is installed and operational the host continues to be compliant with the Part 15B unintentional radiator requirements.
- The information on the label and in the user manual is required to be incorporated in the user manual of the final host. See 47 CFR15 requirements for more details (e.g. 15.19 / 15.21 / 15.101 / 15.105 / RSS-GEN).
- Additional label with the words 'Contains FCC ID: PJMCVEND' and 'Contains IC: 6633A-CVEND' shall be applied and visible from the outside of the host product.
- The module must be installed and used in strict accordance with the manufacturer's instructions as described in the user documentation that comes with the module.
- The power supply for the module must be 5,0 to 5,5 V DC (Ripple < 80 mVpp).
- It is not necessary to shield the module to comply with the FCC / IC requirements. The antenna must not be shielded.
- The antenna of the module may not be removed, replaced nor modified. The antenna must not be co-located or operating in conjunction with any other antenna or transmitter. No additional antenna must be used.

Instructions d'installation pour le fabricant principal

Les changements ou modifications effectués par l'équipement ne sont pas approuvés par FEIG ELECTRONIC, il est possible que GmbH annule l'autorisation du FCC/ IC pour utiliser cet équipement.

L'utilisation de cet émetteur récepteur est autorisée dans les dispositifs fixes ou mobiles en prenant en considération les conditions informées ci-dessous :

- L'intégrateur OEM doit s'assurer que le manuel d'utilisateur ne contient aucune information sur l'installation ou le retrait du module du produit ultime.
- Pour l'ultime dispositif principal, une autre autorisation est requise pour les fonctions de la non-transmission du module émetteur. (ex. Vérification, déclaration ou conformité) Après que le module soit installé et opérationnel, l'intégrateur OEM doit s'assurer que l'hôte continue de se conformer aux exigences du radiateur 15B.
- Les informations sur le label et dans le manuel d'utilisateur doivent être introduites dans le manuel d'utilisateur pour l'ultime hôte. Se référer aux exigences 47 CFR15 pour plus de détails. (ex. 15.19 / 15.21 / 15.101 / 15.105 / RSS-GEN).
- Le label additionnel aux 'Contains FCC ID : PJMCVEND' et 'Contains IC : 6633A-CVEND' doit être appliqué et visible sur le produit hôte.
- Le module doit être installé et utilisé selon les instructions du fabricant dans la documentation d'utilisateur qui est communiquée avec le module.
- L'alimentation du module doit être de 5,0 à 5,5 V DC (tension < 80 mVpp).
- S'il est nécessaire de protéger le module pour se conformer aux exigences du FCC/IC. L'antenne doit être protégée.
- L'antenne du module ne doit pas être retirée, remplacée ni modifiée. Elle ne doit pas être co-implantée ni utilisée conjointement avec d'autres antennes ou émetteurs. Aucune autre antenne ne doit être utilisée.